

High resolution Dome Color Camera LDV-541VN

540TVL, Day & Night, Vandal proof



FEATURES

- 410K Pixel, 1/3" Sony Color CCD
- High Resolution up to 540 TVL
- Digital Day & Night , Privacy Zone, Motion Detection Function
- Built-in OSD (On Screen Display)
- DNR (Digital Noise Reduction) for Reducing HDD capacity
- Easy adjustment with 3 Axis
- Vari-Focal DC Auto Iris Lens (4~9mm)
- Weather-proof (IP65), High-Impact Vandal Proof Dome Housing

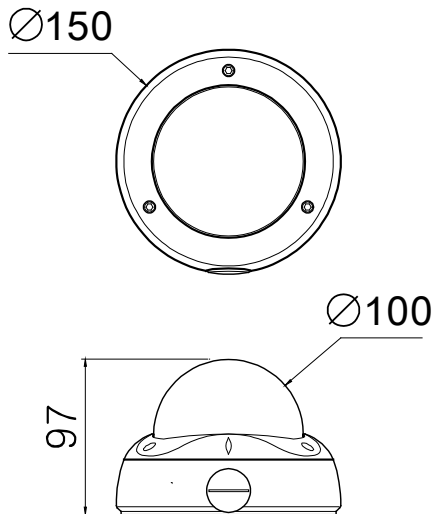

SPECIFICATIONS

MODEL	LDV-541VN	
Signal system	NTSC	PAL
Image Sensor	1/3" Interline Transfer Type Sony CCD	
Total Pixels	811(H)X508(V)	795(H)X596(V)
Effective Pixels	768(H)X494(V)	752(H)X582(V)
Resolution	More than 540 TV lines	
Scanning Frequency	15.734KHz(H), 60(V)	15.625KHz(H), 50(V)
Shutter Speed	1/60~1/100,000 sec	1/50~1/100,000 sec
Min. Illumination	Color : 0.3 Lux, B/W : 0.002 Lux (Sense-up : Auto(2x~128x))	
Day & Night	D&N Function by Digital Change : Auto/Off	
Shutter	ESL / Manual / Flickerless	
White Balance	ATW / AWC / MANUAL	
BLC	Low / Middle / High / Off	
AGC	Low / Middle / High / Off	
DNR	Auto / Off	
Privacy Zone & Motion Detection	4 Programmable Zone	
Sharpness	On(level : 0 ~ 31) / Off	
Camera ID	On / Off	
S/N Ratio	More than 50dB	
Video Output	Composite video output 75 ohm terminated	
Lens	DC auto iris lens (4 ~ 9 mm), F1.6	
Sync. System	Internal	
Operating Humidity	30 % ~ 90 % RH	
Operating Temp.	- 10°C to 50° (14° ~ 122°F)	
Dimension	100 (Bubble) x 103(H)	
Weight	About 1.1 kg (2.4lb)	
Power Consumption	180mA	
Power Supply	DC 12 V(10.2V~14.5 V) AC 24V (Option)	