

High resolution Dome Color Camera LDV-528VNM

520TVL, Day & Night, Vandal proof



FEATURES

- 410K Pixel, 1/3" Sony Color CCD
- High Resolution up to 520 TVL
- Digital Day & Night
- Easy adjustment with 3 Axis
- 3.7mm Fixed Lens,
DC Auto Iris Lens 4~9mm (Option)
- Weather-proof, High-Impact Vandal Proof
Dome Housing

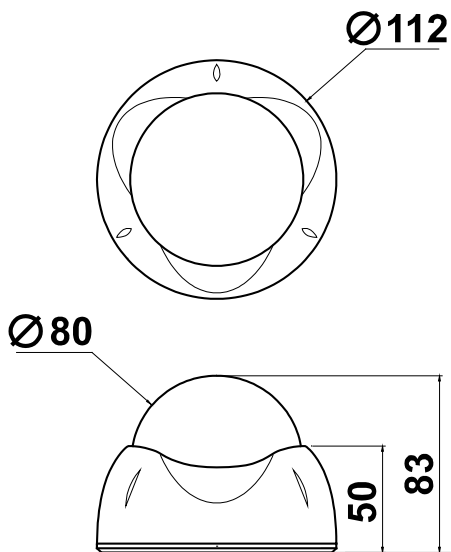

SPECIFICATIONS

MODEL	LDV-528VNM	
Signal system	NTSC	PAL
Image Sensor	SONY 1/3" Sony super HAD Color CCD	
Total Pixels	811(H)X508(V)	795(H)X596(V)
Effective Pixels	768(H)X494(V)	752(H)X582(V)
Resolution	More than 520 TV lines	
Scanning Frequency	15.734KHz(H), 60(V)	15.625KHz(H), 50(V)
Shutter Speed	1/60~1/100,000 sec	1/50~1/100,000 sec
Min. Illumination	0.3 Lux@F1.2	
Day & Night	D&N Function by Digital Change : Auto/Off	
Flickerless	On / Off	
White Balance	Auto	
BLC	On / Off	
AGC	On / Off	
IP Rate	65	
S/N Ratio	More than 50dB	
Video Output	Composite video output 75 ohm terminated	
Lens	3.7mm Fixed lens DC Auto Iris Lens 4~9mm (Option)	
Sync. System	Internal	
Operating Humidity	30 % ~ 90 % RH	
Operating Temp.	- 10°C to 50°C (14 ~ 122°F)	
Materials	Aluminum Body / PC Bubble	
Dimension	80 (Bubble) x 83(H)	
Weight	About 600g (1.3 lb)	
Power Consumption	200mA	
Power Supply	DC 12 V(10.2V~14.5 V)	